



A Tsurumi Pump Company

# PRODUCT DATA SHEET

DGG VORTEX

ZEN-DGG250/4/80HE0ETEX | 807397



IMAGE INDICATIVE ONLY

## PRODUCT DETAILS

The DGG is a cast-iron, submersible vortex pump designed for the transfer and lifting of unscreened biological wastewaters containing suspended solids, soft fibrous material, and sewage. Its setback vortex impeller design keeps solids away from the impeller itself, generating flow through hydraulic action rather than direct mechanical contact, providing clog resistance when handling raw, unscreened waste streams.

## APPLICATIONS

- Residential and civil sewage lifting – sump pits, basement pump-out, and on-site effluent transfer where raw sewage
- Wastewater treatment plants – transfer of raw influent and biological sludges within treatment processes
- Municipal sewer systems – pump stations handling unscreened sewage
- Livestock and agricultural operations – animal waste slurry transfer and yard washdown effluent
- Light industrial applications – process wastewater containing soft organic solids

## FEATURES

- Cast-iron body, impeller and flange EN-GJL250
- AISI 431 motor shaft
- 4-pole, 3-phase motor
- Class H insulation [180°C]
- IP68 protection
- Thermal protections integrated into the stator
- Moisture detection probe fitted to mechanical seal oil chamber
- Two-component epoxy painting 150µm
- Two silicon carbide [SiC] mechanical seals inside the oil chamber
- Cable length 10m

## TECHNICAL DATA

<b>RATED POWER P1 / P2</b>	2.2kW / 1.8kW
<b>MAX. FLOW [Q]</b>	25.4 L/sec
<b>MAX. HEAD [M]</b>	10.3 m
<b>MOTOR INSULATION</b>	H Class
<b>PROTECTION CLASS</b>	IP68
<b>MOTOR PROTECTION</b>	Thermal protection and moisture detection
<b>MOTOR DUTY</b>	Continuous Use S1
<b>MAX. LIQUID TEMPERATURE</b>	40°C
<b>MECHANICAL SEAL</b>	Dual Silicon Carbide
<b>MAX. DENSITY AND PH</b>	1.100 kg/m <sup>3</sup>   pH 6 – 14

<b>RATED VOLTAGE</b>	400V 3ph 50Hz
<b>MOTOR POLES</b>	4-pole
<b>CURRENT</b>	Rated FLC 4.3A DOL current 22.9A
<b>POWER CABLE TYPE</b>	10m H07RN-F Cable
<b>MAX. HYDRAULIC EFFICIENCY</b>	47.8%
<b>FREE PASSAGE</b>	80 mm
<b>IMPELLER TYPE</b>	Set-back vortex impeller
<b>SUCTION</b>	DN80
<b>OUTLET</b>	DN80
<b>WEIGHT (KG)</b>	58.1 kg (pump only)

## CURVE

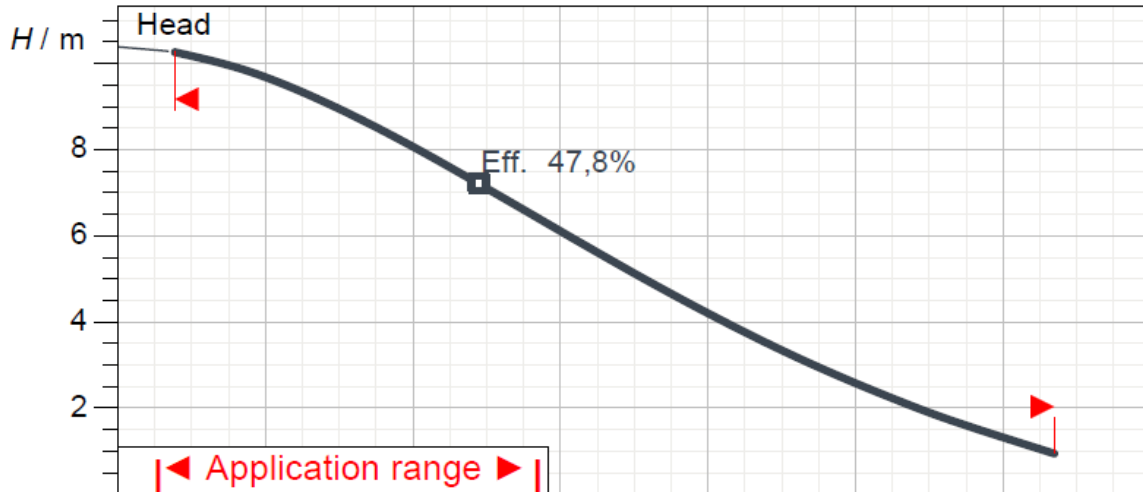

## DIMENSIONS

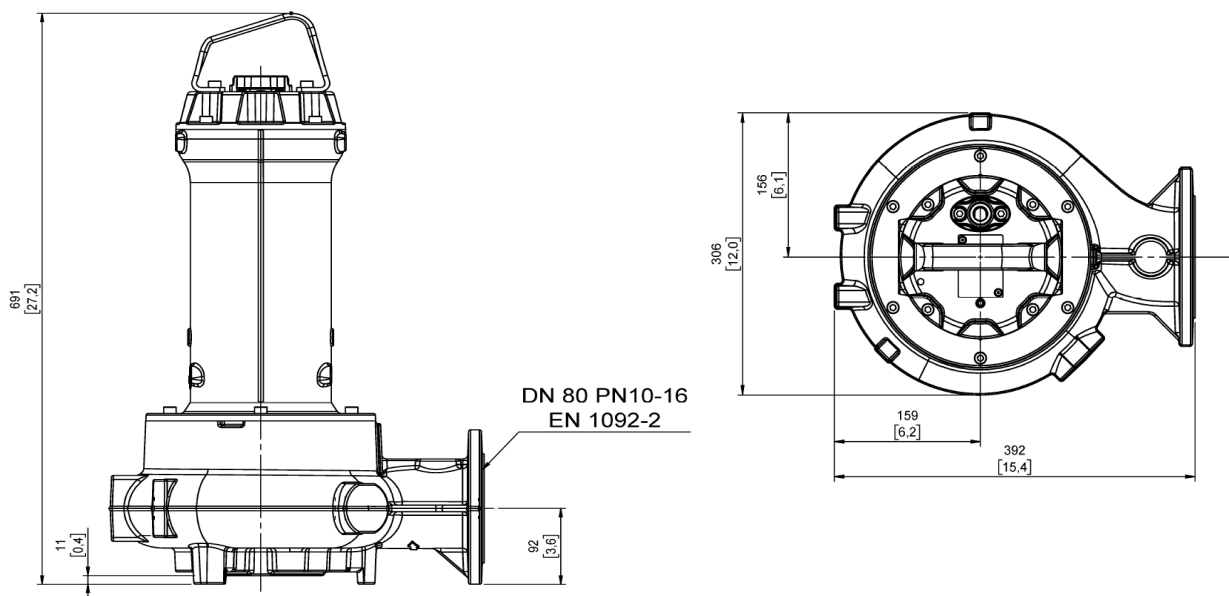

## WARRANTY / CERTIFICATIONS

